

AC-1300S

Features

- ▶ Load Capacity
2,205 lbs/ea | 4,409 lbs w/4
- ▶ Swivel Plate Top
- ▶ Unit Weight **3.44 lbs**



Dimensions

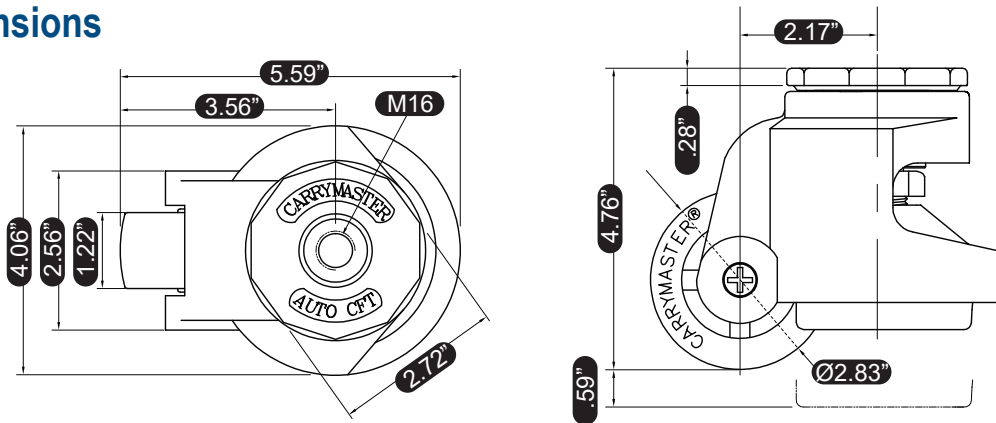

Materials & Treatments

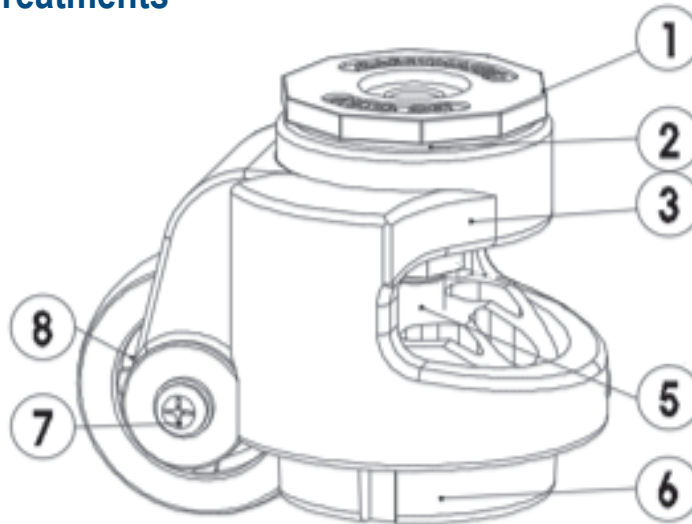

Parts	Materials	Treatments
1	Top Plate	SPC & S45C Zn Galvanized
2	Ball	STB2 Ni-Cr
3	Frame	ALDC12 Powder Coated
5	Leveler	Swrch 10A Zn Galvanized

Parts	Materials	Treatments
6	Foot	NBR Black
7	Pin	Swrch 10A Zn Galvanized
8	Wheel	PA6 Black