

# ACP-200S

## Features

- ▶ Load Capacity  
441 lbs/ea | 882 lbs w/4
- ▶ Swivel Plate Top
- ▶ Unit Weight 1.19 lbs



*\*Available in black*

## Dimensions

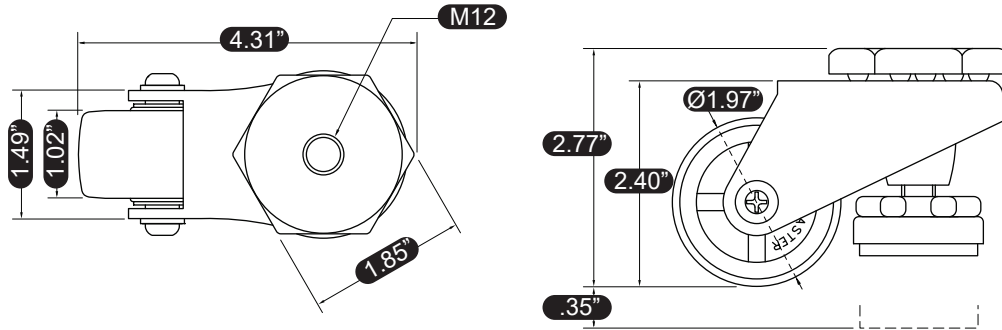

## Materials & Treatments

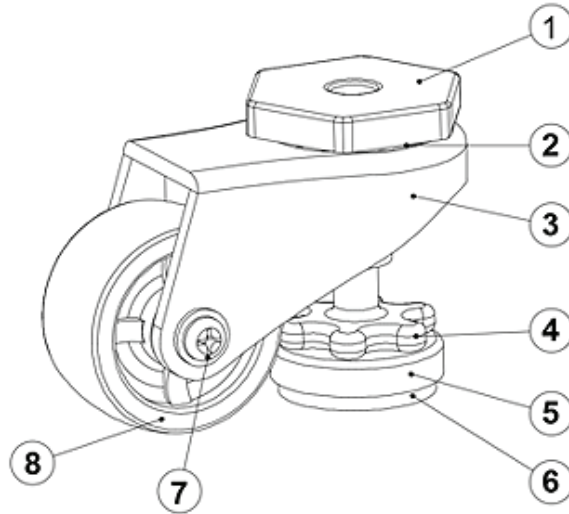

Parts	Materials	Treatments
1	SPC & S45C	Zn Galvanized
2	STB2	Ni-Cr
3	SPC	Zn Galvanized
4	Swrch 10A	Zn Galvanized

Parts	Materials	Treatments
5	SPC	Zn Galvanized
6	NBR & Urethane	Black
7	Swrch 10A	Zn Galvanized
8	PA6	Black