

# ACT-800F

## Features

- ▶ Load Capacity **882 lbs/ea | 1,764 lbs w/4**
- ▶ Swivel Plate Top
- ▶ Unit Weight **1.94 lbs**



## Dimensions

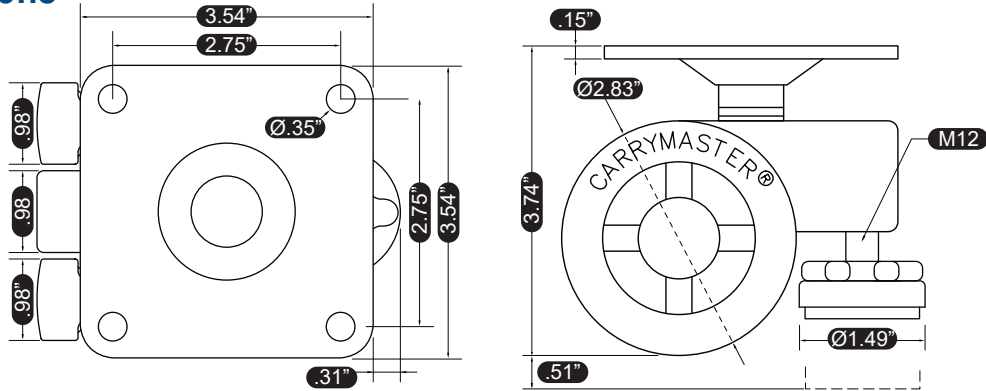

## Materials & Treatments

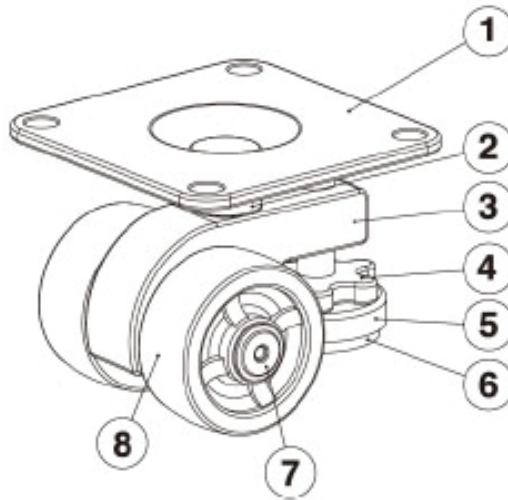

Parts	Materials	Treatments
1	Top Plate	SPC Zn Galvanized
2	Shaft	Swrch 10A Zn Galvanized
3	Frame	ALDC 12 -
4	Leveler	Swrch 10A Zn Galvanized

Parts	Materials	Treatments
5	Cup	SPC Zn Galvanized
6	Foot	NBR & Urethane Black
7	Pin	Swrch 10A Zn Galvanized
8	Wheel	PA6 Black