

# APLC-700F

## Features

- ▶ Load Capacity  
1,543 lbs/ea | 3,086 lbs w/4
- ▶ Swivel Top
- ▶ Unit Weight 3.26 lbs

## Dimensions

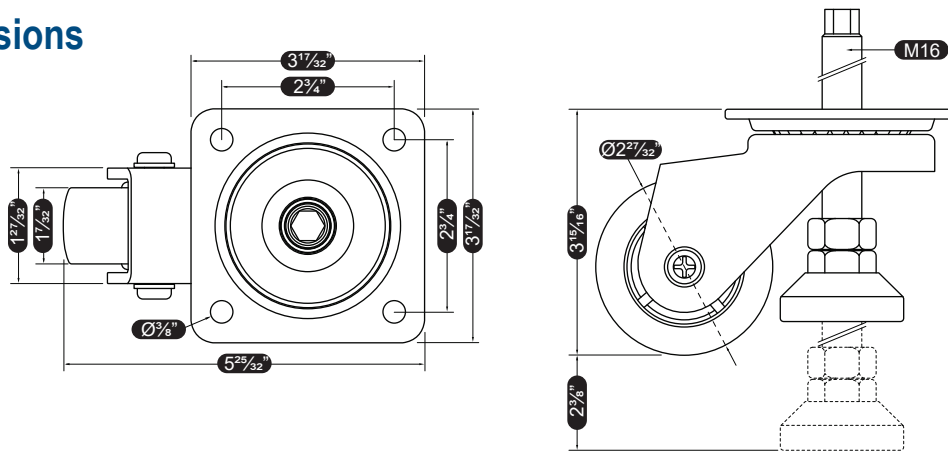

## Materials & Treatments

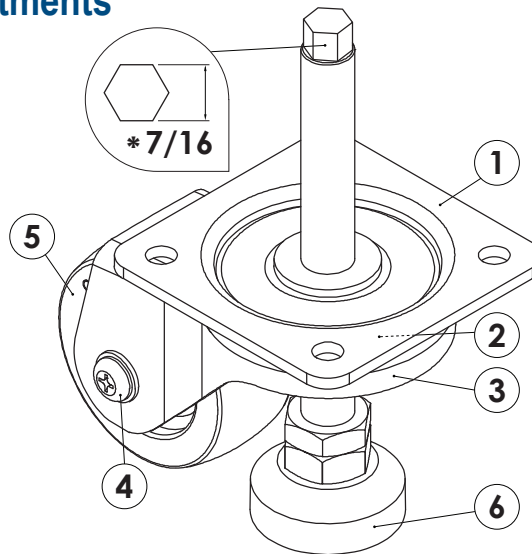

\*Wrench Size in SAE

Parts	Materials	Treatments
1 Top Plate	SPC	Zn Galvanized
2 Ball	STB2	Ni-Cr
3 Frame	SPC	Zn Galvanized

Parts	Materials	Treatments
4 Pin	Swrch 10A	Zn Galvanized
5 Wheel	PA6	Black
6 Foot	S45C	Zn Galvanized